

SECTION A-A

TABLE:

PRODUCT NO.	PACKAGE DOCUMENT	DIM*A"
67503-1020	PK-67503-002	1.00
67503-2020	PK-67503-003	1.00
67503-1030	PK-67503-002	0.80

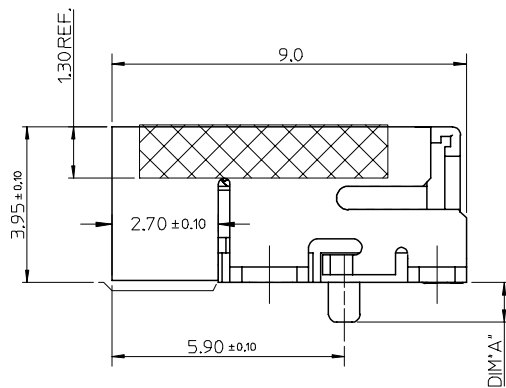
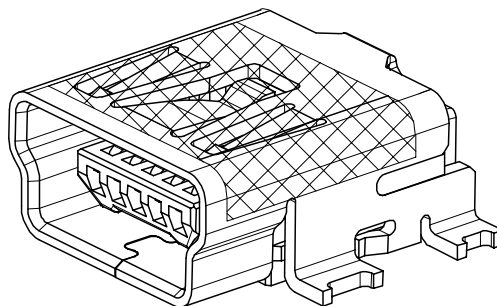

NOTE :

- MATERIAL :  
 HOUSING : NYLON GLASS FILLED , BLACK,UL94V-0  
 TERMINAL : COPPER ALLOY THICKNESS = 0.2 MM  
 SHIELD CASE : COPPER ALLOY THICKNESS = 0.4 MM
- PLATING :  
 TERMINAL:  
 CONTACT AREA : GOLD 0.75 MICROMETER MINIMUM.  
 SOLDER TAIL AREA : PURE TIN 1~3 MICROMETER PLATING.  
 UNDER PLATING : NICKEL 1.25 MICROMETER MINIMUM.  
 SHIELD CASE :  
 PURE TIN 1~3 MICROMETER PLATING.  
 UNDER PLATING : NICKEL 1.0 MICROMETER MINIMUM.
- TAIL & NAIL COPLANARITY 0.1 mm MAXIMUM.
- PRODUCT SPECIFICATION REFER TO PS-67803-001.
- PACKAGING INFORMATION REFER TO TABLE.

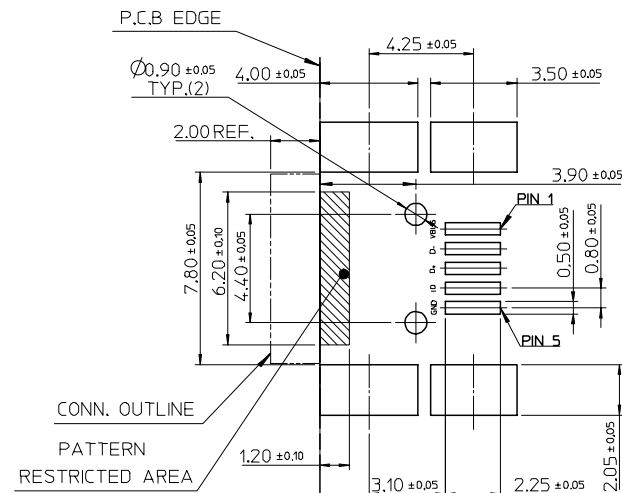

RECOMMENDED P.C.B. PATTERN LAYOUT

ADD MATERIAL NUMBER EC NO: SH2006-0191 DRWN:X/SONG CHKD: APPR:GCHEN	2005/10/31 2005/10/31 2005/11/08	DESCRIPTION
REV		

QUALITY SYMBOLS	▽=0 ▽C=0
-----------------	-------------

GENERAL TOLERANCES (UNLESS SPECIFIED)	mm	INCH
4 PLACES	± ---	± ---
3 PLACES	± ---	± ---
2 PLACES	± 0.25	± ---
1 PLACE	± 0.25	± ---
ANGULAR ± 3 °		
DRAFT WHERE APPLICABLE MUST REMAIN WITHIN DIMENSIONS		

DIMENSION STYLE MM ONLY		SCALE 8:1	DESIGN UNITS METRIC	THIRD ANGLE PROJECTION
DRAWN BY XWANG	DATE 2004/11/29	TITLE USB SERIES MINI-B REC. ASS'Y SMT TYPE (LEAD FREE)		
CHECKED BY HARVEY	DATE 2004/11/29	APPROVED BY YTYAP		
MATERIAL NO. SEE TABLE		DOCUMENT NO. SD-67503-010	SHEET NO. 1 OF 1	

MOLEX INCORPORATED				
THIS DRAWING CONTAINS INFORMATION THAT IS PROPRIETARY TO MOLEX INCORPORATED AND SHOULD NOT BE USED WITHOUT WRITTEN PERMISSION				